

RSM-2

REMOTE SPEAKER/ MICROPHONE KIT

For Use With the Dual 824
Security System

Installation Instructions

Linear[®]

(760) 438-7000 • FAX (760) 438-7043
USA & Canada (800) 421-1587 & (800) 392-0123
Toll Free FAX (800) 468-1340
www.linearcorp.com

PRODUCT DESCRIPTION

The Model RSM-2 Remote Speaker/Microphone kit is designed for use with Linear's Model Dual 824 Security System. When a Model VB-2 or VB-3 audio module is installed in the Dual 824 control panel, the RSM-2 speaker and microphone provide sound and audio monitoring at the keypad. The RSM-2 speaker mounts inside the DUAL 824KP keypad. Four locking push-on washers secure the speaker to the keypad case. The speaker will sound voice prompts for operating the system from the VB-2 or VB-3 module installed in the DUAL 824 control panel. With the Model VB-2 installed, the Central Station can talk to the subscriber through the RSM-2 speaker. The RSM-2 microphone presses into a recess designed into the keypad's case. With the Model VB-2 installed into the DUAL 824 control panel, the Central Station can monitor sounds in the installation. THE MODEL VB-3 AUDIO MODULE DOES NOT SUPPORT AUDIO MONITORING AND DOES NOT REQUIRE INSTALLATION OF THE MICROPHONE.

1. KIT COMPONENTS

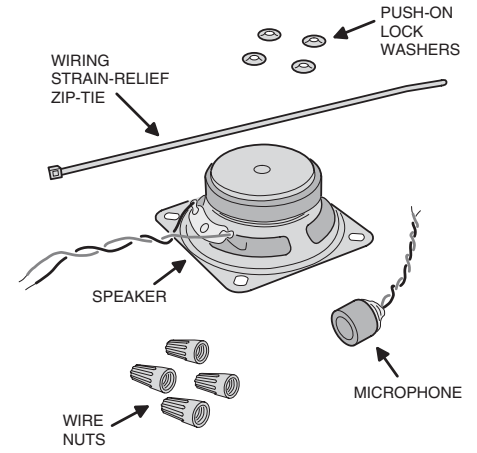

2. OPEN KEYPAD

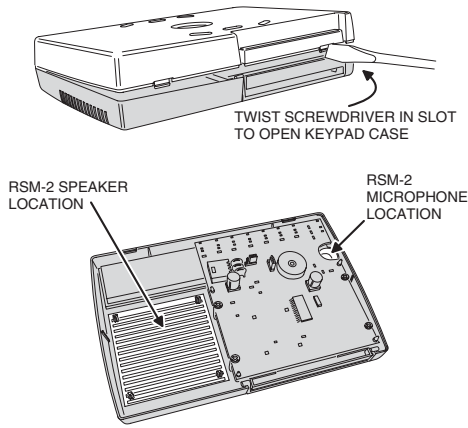

3. MOUNT SPEAKER & MICROPHONE

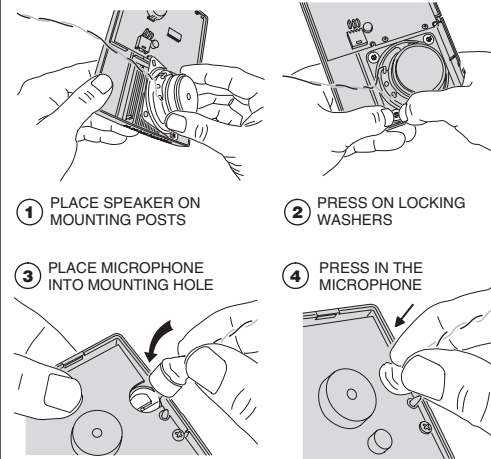

4. ROUTE WIRING

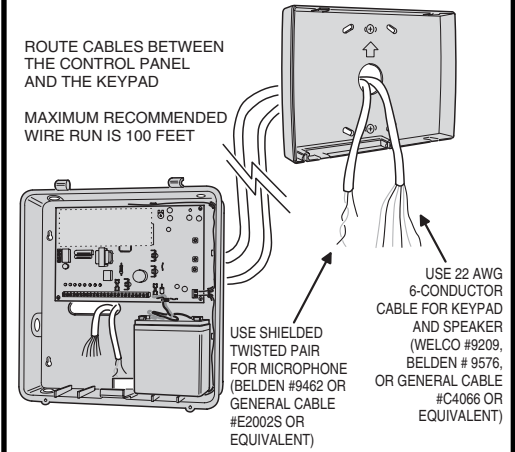

5. CONTROL PANEL CONNECTIONS

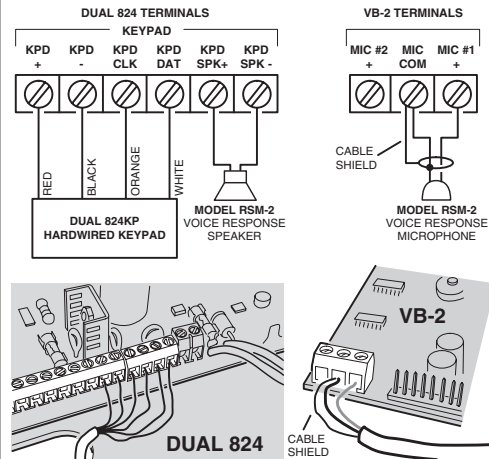

6. INSTALL VOICE BOARD

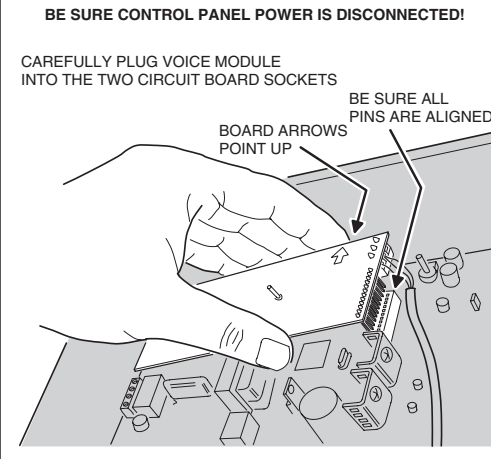

7. KEYPAD CONNECTIONS

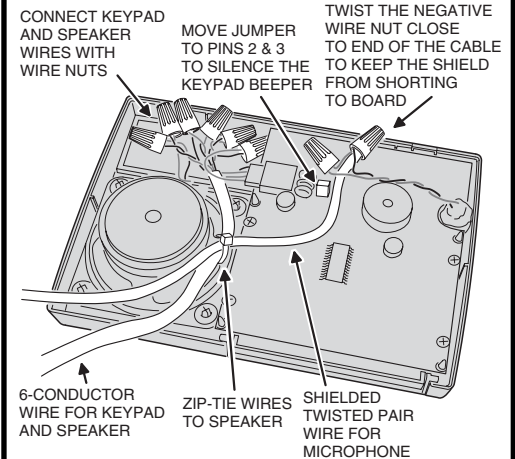

8. VOICE SYNTHESIS SETUP

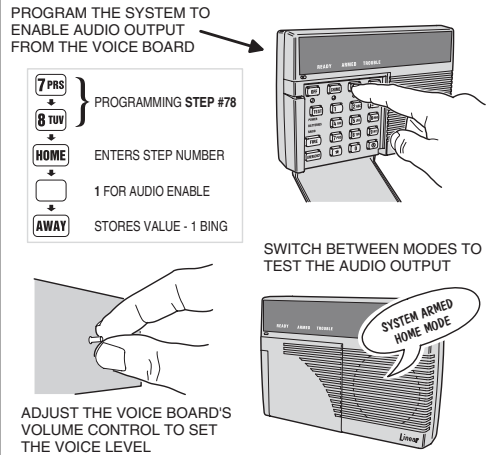

9. REMOTE SYSTEM OPERATION

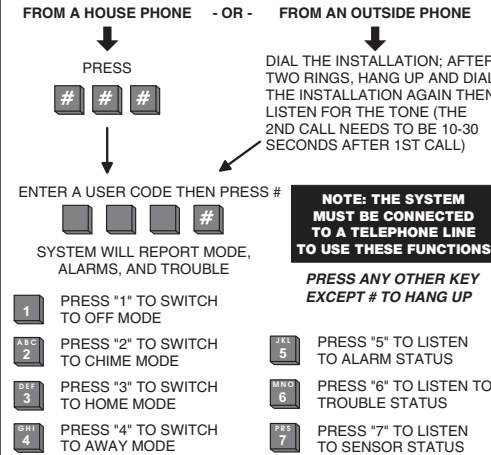

LINEAR LIMITED WARRANTY

This Linear product is warranted against defects in material and workmanship for twelve (12) months. The Warranty Expiration Date is labeled on the product. This warranty extends only to wholesale customers who buy direct from Linear or through Linear's normal distribution channels. Linear does not warrant this product to consumers. Consumers should inquire from their selling dealer as to the nature of the dealer's warranty, if any. There are no obligations or liabilities on the part of Linear corporation for consequential damages arising out of or in connection with use or performance of this product or other indirect damages with respect to loss of property, revenue, or profit, or cost of removal, installation, or reinstallation. All implied warranties, including implied warranties for merchantability and implied warranties for fitness, are valid only until Warranty Expiration Date as labeled on the product. This Linear Corporation Warranty is in lieu of all other warranties express or implied.

All products returned for warranty service require a Return Product Authorization Number (RPA#). Contact Linear Technical Service at 1-800-421-1587 for an RPA# and other important details.

IMPORTANT!!!

Linear radio controls provide a reliable communications link and fill an important need in portable wireless signalling. However, there are some limitations which must be observed.

- For U.S. installations only: The radios are required to comply with FCC Rules and Regulations as Part 15 devices. As such, they have limited transmitter power and therefore limited range.
- A receiver cannot respond to more than one transmitted signal at a time and may be blocked by radio signals that occur on or near their operating frequencies, regardless of code settings.
- Changes or modifications to the device may void FCC compliance.
- Infrequently used radio links should be tested regularly to protect against undetected interference or fault.
- A general knowledge of radio and its vagaries should be gained prior to acting as a wholesale distributor or dealer, and these facts should be communicated to the ultimate users.

Copyright © 2001 Linear Corporation 218234 A