

# DXS-32

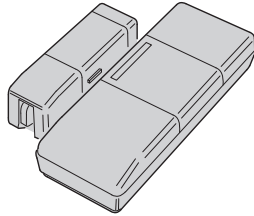

## MINIATURE SUPERVISED DOOR/WINDOW TRANSMITTER

### Installation Instructions



USA & Canada (800) 421-1587 & (800) 392-0123  
(760) 438-7000 - Toll Free FAX (800) 468-1340  
www.linearcorp.com

### PRODUCT DESCRIPTION

The DXS-32 is a battery powered stationary transmitter designed for use with Linear's DXS and DX format receivers. This transmitter can be used in a variety of wireless remote control applications. Triggering the transmitter with its built-in magnetic switch sends a digitally coded wireless signal to its companion receiver.

The digital DXS code format features over a million possible codes. The DXS transmitters are precoded at the factory to unique codes, so no field coding is required. The DXS-32 can send four different codes: alarm, restore, low battery and status.

Receivers must be programmed to the transmitter's code before system testing and operation. Refer to the receiver's instructions for details on programming.

In a typical installation, the magnet is mounted on a door or window and the transmitter is mounted on the frame. When the magnet moves more than 1/2" away from the transmitter, an alarm signal is sent. When the magnet returns next to the unit, a restore signal is sent. The magnet is adjustable with four height positions. A 1/4" high magnet spacer is also supplied to snap on to the base of the magnet.

The transmitter is powered from two 3-Volt #2032 lithium batteries with an expected battery life of up to 4 years. Every hour, the DXS-32 will send a status transmission to the receiver. The hourly signal updates the receiver to the transmitter's condition. By monitoring status transmissions, the receiver can determine if a transmitter has a low battery or has been removed from the system. DXS format receivers can monitor status signals, DX format receivers cannot.

Normally, the transmitter sends an exit/entry delay transmission code. Cutting an internal jumper selects an instant transmission code. Cutting this jumper doesn't change the time of the actual transmissions, but changes the code of the signal sent so the receiver can determine the transmitter's function.

### DXS-32 FEATURES & ACCESSORIES

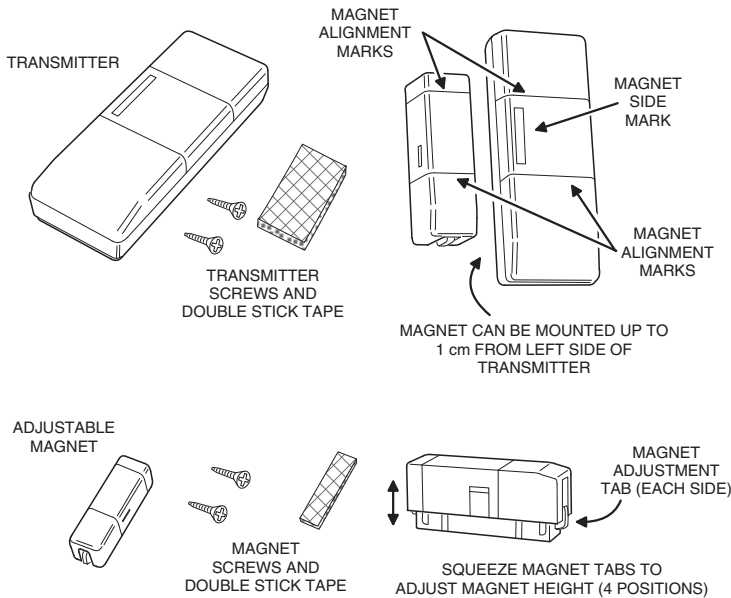

### OPENING CASE

REMOVE THE CASE TOP BY TWISTING A SMALL FLAT BLADE SCREWDRIVER IN THE SLOT ON EITHER END OF THE TRANSMITTER

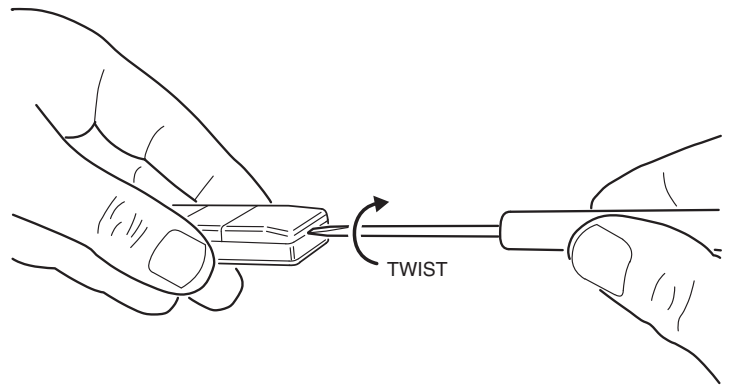

### REMOVE BATTERY PROTECTION STRIP

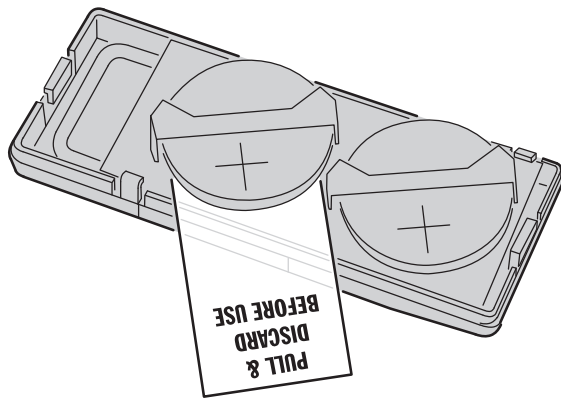

PULL OUT & DISCARD BATTERY PROTECTION STRIP TO ACTIVATE TRANSMITTER

### COMPONENT LOCATIONS

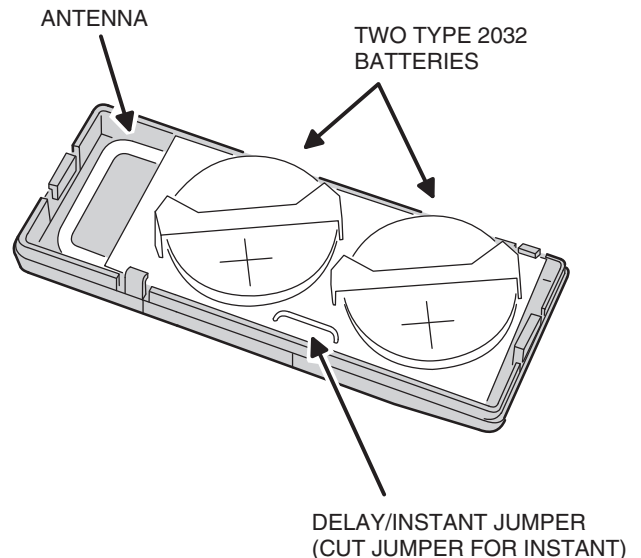

## EXAMPLE INSTALLATIONS

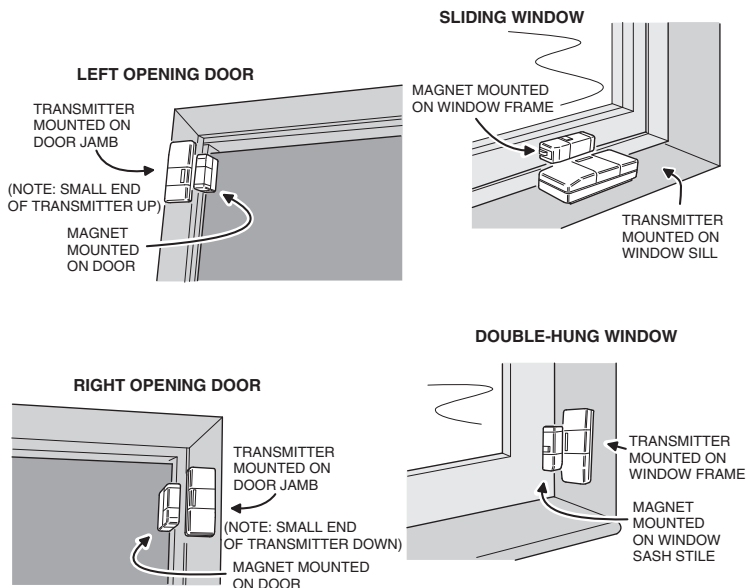

## TRANSMITTER MOUNTING

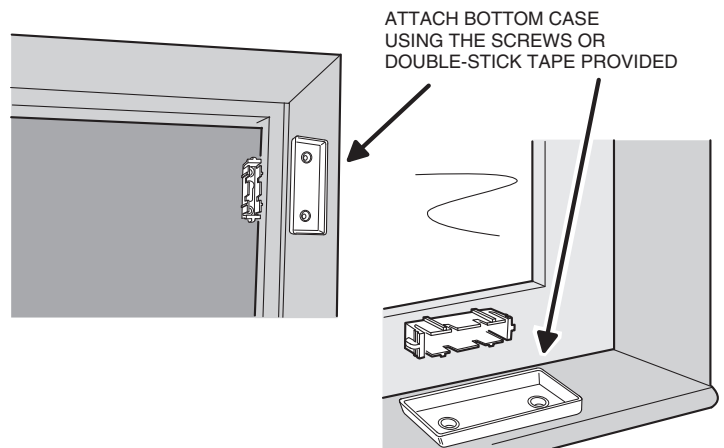

**NOTE: ATTACHING THE TRANSMITTER WITH DOUBLE-STICK TAPE IS NOT ALLOWED IN UL INSTALLATIONS**

## ADJUSTING MAGNET HEIGHT

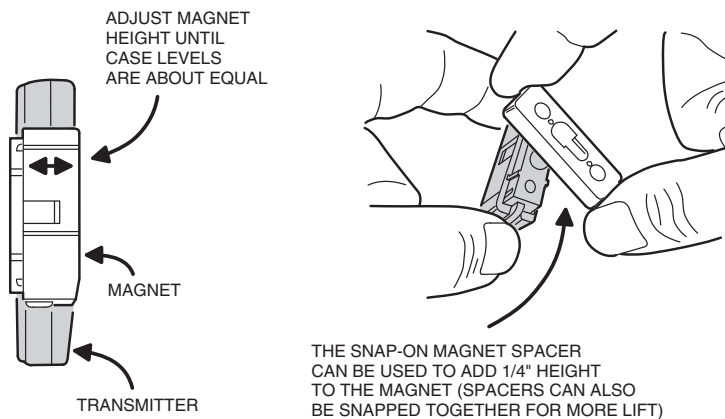

## PROGRAMMING RECEIVER

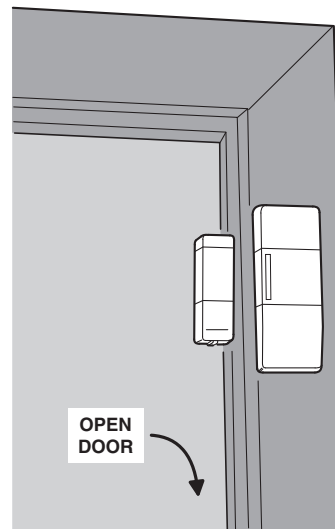

### PROGRAMMING:

1. PLACE RECEIVER INTO PROGRAM OR "LEARNING" MODE
2. ACTIVATE TRANSMITTER BY OPENING DOOR OR WINDOW
3. VERIFY THAT THE RECEIVER ACCEPTED THE SIGNAL

### TESTING:

1. PLACE RECEIVER INTO TEST MODE
2. OPEN DOOR, VERIFY THAT THE RECEIVER INDICATES AN OPEN DOOR
3. CLOSE DOOR, VERIFY THAT THE RECEIVER RECOGNIZED THAT THE DOOR IS CLOSED

## CHANGING BATTERIES

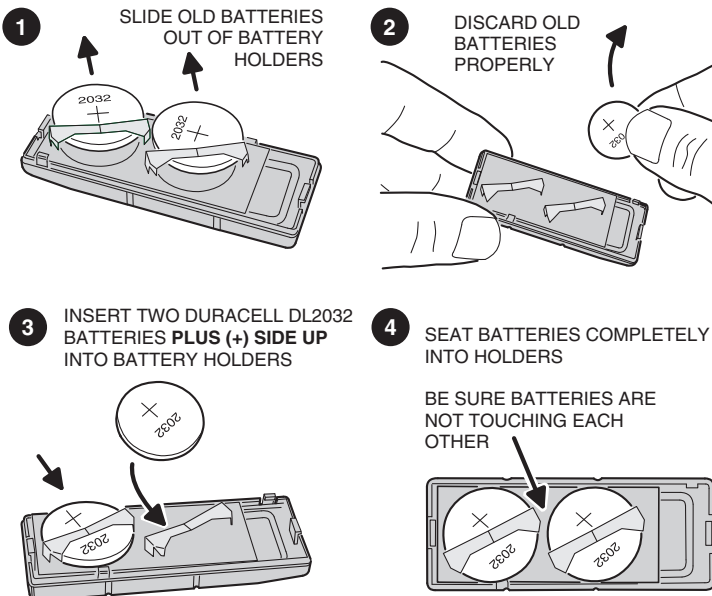

## LINEAR LIMITED WARRANTY

This Linear product is warranted against defects in material and workmanship for twelve (12) months. **This warranty extends only to wholesale customers** who buy direct from Linear or through Linear's normal distribution channels. Linear does not warrant this product to consumers. Consumers should inquire from their selling dealer as to the nature of the dealer's warranty, if any. **There are no obligations or liabilities on the part of Linear LLC for consequential damages arising out of or in connection with use or performance of this product or other indirect damages with respect to loss of property, revenue, or profit, or cost of removal, installation, or reinstallation.** All implied warranties, including implied warranties for merchantability and implied warranties for fitness, are valid only until the warranty expires. **This Linear LLC Warranty is in lieu of all other warranties express or implied.**

All products returned for warranty service require a Return Product Authorization Number (RPA#). Contact Linear Technical Services at 1-800-421-1587 for an RPA# and other important details.

### FCC NOTE:

This device complies with FCC Part 15 and IC Canada Rules and Regulations. Operation is subject to the following two conditions: (1) This device may not cause harmful interference and (2) this device must accept any interference received, including interference that may cause undesired operation.

### IMPORTANT !!!

Linear radio controls provide a reliable communications link and fill an important need in portable wireless signaling. However, there are some limitations which must be observed.

- \* For U.S. installations only: The radios are required to comply with FCC Rules and Regulations as Part 15 devices. As such, they have limited transmitter power and therefore limited range.
- \* A receiver cannot respond to more than one transmitted signal at a time and may be blocked by radio signals that occur on or near their operating frequencies, regardless of code settings.
- \* Changes or modifications to the device may void FCC compliance.
- \* Infrequently used radio links should be tested regularly to protect against undetected interference or fault.
- \* A general knowledge of radio and its vagaries should be gained prior to acting as a wholesale distributor or dealer, and these facts should be communicated to the ultimate users.