

DUAL 824KP

HARDWIRED KEYPAD

For Use with DUAL 824P Control Panel

Installation Instructions

Linear

(760) 438-7000 • FAX (760) 438-7043
USA & Canada (800) 421-1587 & (800) 392-0123
Toll Free FAX (800) 465-1340
www.linearcorp.com

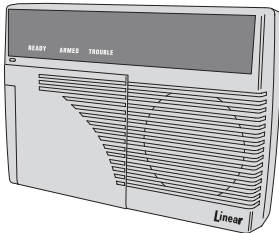

DESCRIPTION

The DUAL 824KP digital keypad is designed for use with Linear's DUAL 824P control panel. The keypad is used to arm, disarm and interrogate the security system. Audible alarm signals and sirens sound from the built-in sounder. The keypad sounds a chirp as each key is pressed (the sounder can be disabled with an internal jumper). The installer can program the control panel directly from the keypad or by using the RA-2400 Remote Access Software. A swing-down "beauty cover" conceals the keyboard, mode and lower status indicators. On the inside of the cover there is an area to apply sensor location labels for up to 24 sensors.

The green READY indicator lights when all sensors are closed, showing that the system is ready to arm. The ARMED indicator blinks during the exit delay and lights steady when the system is fully armed. The yellow TROUBLE indicator lights when there is power, sensor battery, or sensor radio supervisory conditions.

The 24 red sensor status indicators (numbered 1-24) are visible on the unit's blackout faceplate only when lit. They light to show an open sensor, they flash to show alarm memory. The sensor status indicators also light during interrogation to pinpoint sensor trouble conditions. Five green indicators next to the mode keys show the system's current mode. The green POWER indicator normally lights steady and will blink when panel's backup battery is low, recharging, or missing. The yellow BATTERIES or RADIO indicators will flash for transmitter low battery or supervisory trouble.

The keypad has two buttons for 24-hour activation. The FIRE and EMERGENCY buttons can be pressed at any time for immediate activation (press and hold either button for 3 seconds to trigger system).

When a voice response module (Model VB-2 or VB-3) is installed in the control panel, and the Model RSM-2 remote speaker-microphone kit is installed in the keypad, the keypad will sound vocal operating prompts. For audio listen-in capabilities with the Model VB-2, a location for mounting a microphone is provided in the keypad (shielded cable required).

Connection to the control panel is made through a 4-wire cable. One or two keypads can be connected to the control panel. The keypad select jumper inside the keypad can be set to KEYPAD 1 or KEYPAD 2. Wiring can be "daisy-chained" (panel to keypad 1, keypad 1 to keypad 2) or "home-run" (panel to keypad 1, panel to keypad 2).

1. OPEN CASE, LOCATE COMPONENTS & SET JUMPERS

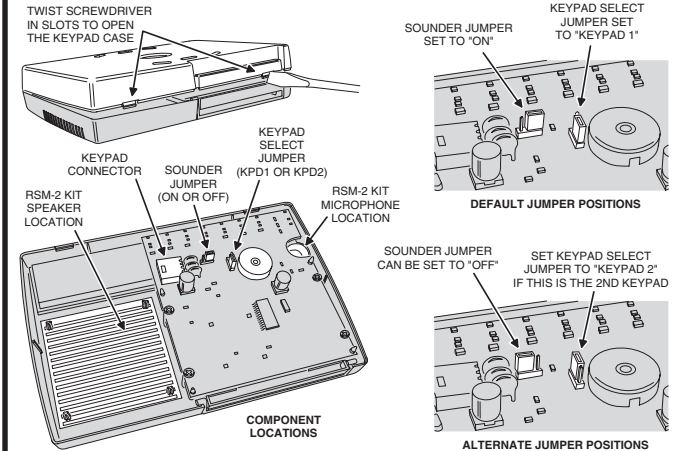

2. INSTALL MOUNTING PLATE

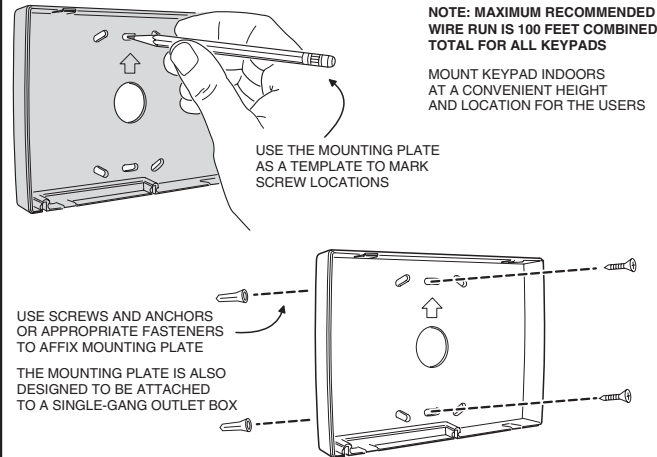

3. CONNECT WIRING

ROUTE 4-CONDUCTOR 22 AWG WIRE OR LARGER FROM CONTROL PANEL TO KEYPAD

DUAL 824P CONTROL PANEL



TO DUAL 824KP KEYPAD

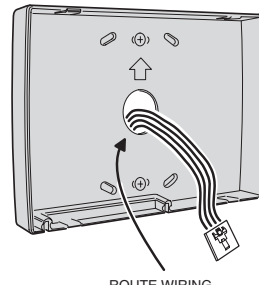

ROUTE WIRING CONNECTOR THROUGH MOUNTING PLATE HOLE

IF THE RSM-2 SPEAKER/MICROPHONE KIT IS GOING TO BE USED, RUN AN ADDITIONAL PAIR FOR THE SPEAKER AND A SHIELDED PAIR FOR THE MICROPHONE

4. PLUG-IN CABLE CONNECTOR AND MOUNT KEYPAD

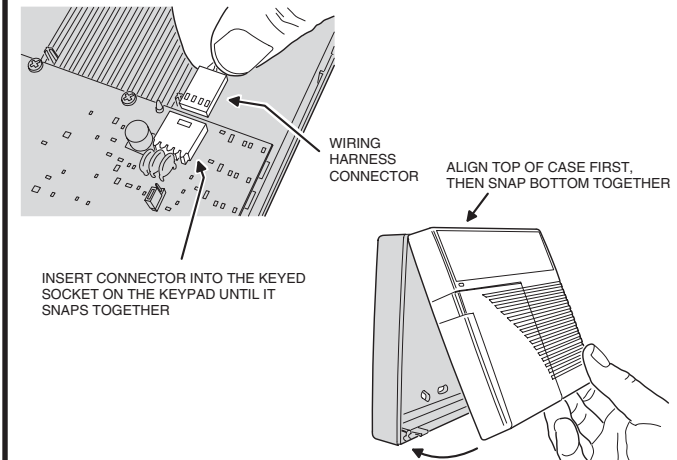

5. TEST KEYPAD

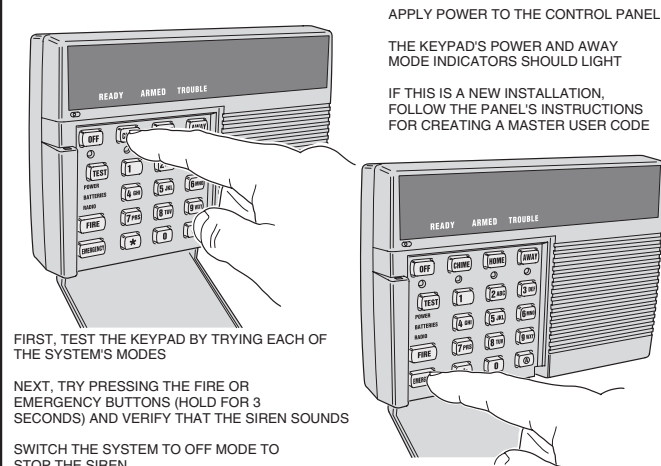

6. CUSTOMIZE KEYPAD

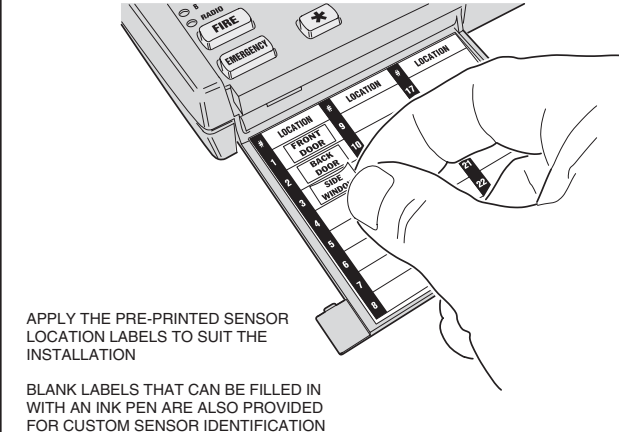

LINEAR LIMITED WARRANTY

This Linear product is warranted against defects in material and workmanship for twelve (12) months. The Warranty Expiration Date is labeled on the product. **This warranty extends only to wholesale customers** who buy direct from Linear or through Linear's normal distribution channels. **Linear does not warrant this product to consumers.** Consumers should inquire from their selling dealer as to the nature of the dealer's warranty, if any. **There are no obligations or liabilities on the part of Linear Corporation for consequential damages arising out of or in connection with use or performance of this product or other indirect damages with respect to loss of property, revenue, or profit, or cost of removal, installation, or reinstallation.** All implied warranties, including implied warranties for merchantability and implied warranties for fitness, are valid only until Warranty Expiration Date as labeled on the product. **This Linear Corporation Warranty is in lieu of all other warranties express or implied.**

All products returned for warranty service require a Return Product Authorization Number (RPA#). Contact Linear Technical Services at 1-800-421-1587 for an RPA# and other important details.