

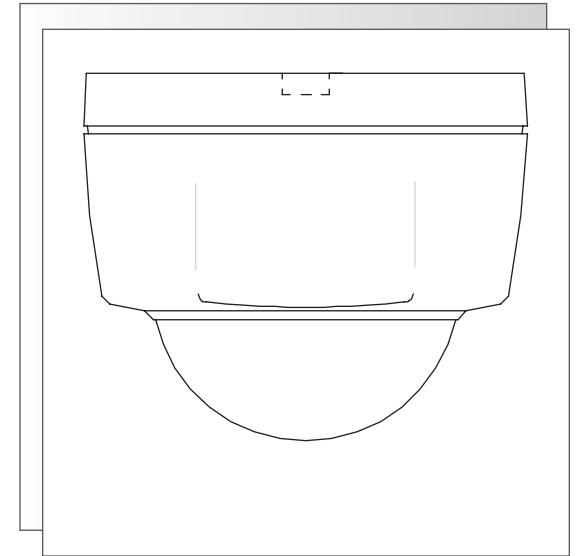

MINILINE INDOOR FIXED DOMES



MLP FIXED-FOCAL SERIES

SAFETY PRECAUTIONS

	CAUTION RISK OF ELECTRIC SHOCK. DO NOT OPEN!	
<p>CAUTION: TO REDUCE THE RISK OF ELECTRICAL SHOCK, DO NOT OPEN COVERS. NO USER SERVICEABLE PARTS INSIDE. REFER SERVICING TO QUALIFIED SERVICE PERSONNEL.</p>		

This label may appear on the bottom of the unit due to space limitations.



The lightning flash with an arrowhead symbol within an equilateral triangle is intended to alert the user to the presence of uninsulated "dangerous voltage" within the product's enclosure that may be of sufficient magnitude to constitute a risk of electric shock to persons.



The exclamation point within an equilateral triangle is intended to alert the user to presence of important operating and maintenance (servicing) instructions in the literature accompanying the appliance.



WARNING: TO PREVENT FIRE OR SHOCK HAZARD, DO NOT EXPOSE UNITS TO RAIN OR MOISTURE.



Attention: Installation should be performed by qualified service personnel only in accordance with the National Electrical Code or applicable local codes.

24 VAC Units: Do Not Exceed 30 VAC Input. Voltage applied to the unit's power input should not exceed 30 VAC. Normal input voltage is 24 VAC. User supplied wiring from 24 VAC supply to unit must be in compliance with electrical codes (Class 2 power levels). Do not ground 24 VAC supply at power supply terminals or at unit's power supply terminals.

SECURITE

	ATTENTION RISQUE D'ÉLECTROCUTION. NE PAS OUVRIR	
<p>DANGER: POUR ÉVITER TOUT RISQUE D'ÉLECTROCUTION, NE PAS OUVRIR LE BOÎTIER. IL N'Y A PAS DE PIÈCES REMPLAÇABLES À L'INTÉRIEUR. POUR TOUTE RÉVISION, S'ADRESSER À UN TECHNICIEN SPÉCIALISÉ.</p>		

En raison de limitation de place, cette étiquette peut être placée sur le dessous de l'appareil.



L'éclair fléché dans un triangle équilatéral, avertit l'utilisateur de la présence d'une "tension dangereuse" non isolée à l'intérieur de l'appareil et d'une valeur suffisante pour constituer un risque d'électrocution.



Le point d'exclamation contenu dans un triangle équilatéral, avertit l'utilisateur de la présence, dans la documentation qui accompagne l'appareil, de consignes d'utilisation et de maintenance importantes.

ATTENTION: POUR ÉVITER LE RISQUE D'ÉLECTROCUTION OU D'INCENDIE, NE PAS EXPOSER À LA PLUIE OU À L'HUMIDITÉ UN APPAREIL.





Attention: L'installation doit être effectuée uniquement par du personnel de service qualifié conformément à la réglementation du Code Electrique National ou à la réglementation locale.

Appareils 24 VCA

Ne pas excéder 30 VCA. La tension appliquée à l'entrée d'alimentation de l'appareil ne devrait pas excéder 30 VCA. Toute installation électrique fournissant du 24 Volts courant alternatif doit être conforme aux codes électriques. (Niveaux d'alimentation de la Classe 2). Ne pas brancher une prise de terre sur les bornes d'alimentation 24 Volts ou aux bornes d'alimentation de l'appareil.

SICHERHEITSVORKEHRUNGEN

	VORSICHT RISICO EINES ELEKTRISCHEN SCHLAGES NICHT OFFNEN!	
<p>VORSICHT: UM EINEN ELEKTRISCHEN SCHLAG ZU VERMEIDEN, ABDECKUNG NICHT ENTFERNEN. WARTUNGEN ALLER ART QUALIFIZIERTEM PERSONAL ÜBERLASSEN.</p>		

Aus Platzgründen kann diese Warnung auf der Unterseite des Gerätes angebracht sein.



Das Blitzsymbol im gleichseitigen Dreieck soll den Benutzer auf nicht isolierte "Hochspannung" im Gehäuse aufmerksam machen, die eventuell stark genug ist, um einen elektrischen Schlag zu verursachen.



Das Ausrufezeichen im gleichseitigen Dreieck soll den Benutzer auf wichtige Bedienungs- und Wartungsanleitungen in der dem Gerät beigefügten Literatur aufmerksam machen.

WARNUNG: UM FEUER ODER ELEKTRISCHE SCHLÄGE ZU VERMEIDEN, SETZEN SIE DAS GERÄT NIEMALS REGEN ODER FEUCHTIGKEIT AUS.



Achtung! Die Installation sollte nur von qualifiziertem Kundendienstpersonal gemäß jeweilig zutreffender Elektrovorschriften ausgeführt werden.

24 VAC Geräte

Achtung! 30 Volt Eingangsspannung darf für 24 VAC Modelle nicht überschritten werden. Normal-betrieb findet bei 24 Volt Wechselspannung statt. Die Kabel- bzw. Drahtverbindung vom Netzgerät zu dem vorliegenden Gerät muß die Bestimmungen der Schutz-klasse II erfüllen. Nicht die 24-Volt-Leitung erden weder am Netzgerät noch an den Anschlußklemmen des vorliegenden Gerätes

PRECAUCIONES DE SEGURIDAD

	PRECAUCION RIESGO DE CHOQUE ELECTRICO INO ABRIR!!	
<p>PRECAUCION: PARA REDUCIR EL RIESGO DE CHOQUE ELÉCTRICO, FAVOR NO ABRIR LA CUBIERTA. ESTE EQUIPO NO CONSTA DE PIEZAS O PARTES QUE REQUIEREN SERVICIO O MANTENIMIENTO. PARA REPARACIONES FAVOR REFERIRSE A UN TÉCNICO CALIFICADO.</p>		

Debido a limitaciones de espacio, esta etiqueta puede aparecer en la parte inferior de la unidad.



El símbolo representado por un relámpago con punta de flecha dentro de un triángulo equilátero, se muestra con el objetivo de alertar al usuario que existen "voltajes peligrosos" sin aislamiento, dentro de la cubierta de la unidad. Dichos voltajes pueden ser de tal magnitud que constituyen un riesgo de choque eléctrico a personas.



El símbolo de exclamación dentro de un triángulo equilátero, se muestra con el objetivo de alertar al usuario de que instrucciones de operación y mantenimiento importantes acompañan al equipo.

PELIGRO: PARA EVITAR EL PELIGRO DE INCENDIO Ó CHOQUE ELÉCTRICO, NO EXPONGA A LA LLUVIA Ó HUMEDAD.



Atención: La instalación de este equipo debe ser realizada por personal capacitado, solo en acuerdo, y en cumplimiento de normas del "National Electric Code" (Código Eléctrico Nacional) ó las normas del Gobierno Nacional Local.

Unidades de 24 VCA

No exceder 30 VCA de entrada. Voltage suplido a la unidad no debe exceder 30 VCA. Voltage de entrada normal es de 24 VCA. El cableado de 24 VCA provisto por el usuario debe cumplir con las normas eléctricas (Clase 2 de niveles de alimentación). No conectar los 24 VCA a tierra en las terminales de la alimentación ó a las terminales de la fuente de alimentación de la unidad.

FCC & ICES INFORMATION

(U.S.A. and Canadian Models Only)

WARNING - This equipment has been tested and found to comply with the limits for a Class A digital device, pursuant to Part 15 of the FCC Rules and ICES-003 of Industry Canada. These limits are designed to provide reasonable protection against harmful interference when the equipment is operated in a commercial environment. This equipment generates, uses, and can radiate radio frequency energy and, if not installed and used in accordance with the instruction manual, may cause harmful interference to radio communications. Operation of this equipment in a residential area is likely to cause harmful interference in which case the user will be required to correct the interference at his own expense. Intentional or unintentional changes or modifications not expressly approved by the party responsible for compliance shall not be made. Any such changes or modifications could void the user's authority to operate the equipment.

If necessary, the user should consult the dealer or an experienced radio/television technician for corrective action. The user may find the following booklet prepared by the Federal Communications Commission helpful: "How to Identify and Resolve Radio-TV Interference Problems." This booklet is available from the U.S. Government Printing Office, Washington, DC 20402, Stock No.004-000-00345-4.

Warning: This is a Class A product. In a domestic environment, this product may cause radio interference in which case the user may be required to take adequate measures.

1. UNPACKING

Unpack carefully. This is an electromechanical device and should be handled carefully. Check to ensure that the following items are included:

- Integrated camera/housing unit
- Hardware kit containing 2 6-32 x 3/4 mounting screws

If an item appears to have been damaged in shipment, replace it properly in its carton and notify the shipper. If any items are missing, notify Aigis Mechtronics. The shipping carton is the safest container in which the unit may be transported. Save it for possible future use.

2. SERVICE

If the unit ever needs repair service or parts, the customer should contact Aigis Mechtronics for authorization to return and shipping instructions.

3. DESCRIPTION

The MLP Fixed-Focal Series are small, discreet surveillance domes containing fixed high performance 1/4-inch CCD cameras. The one-piece module is easily mounted to a single gang electrical box directly to a wall or ceiling. The units come ready to use and have line lock, phase adjustment, and backlight compensation controls to ensure the highest quality image and performance.

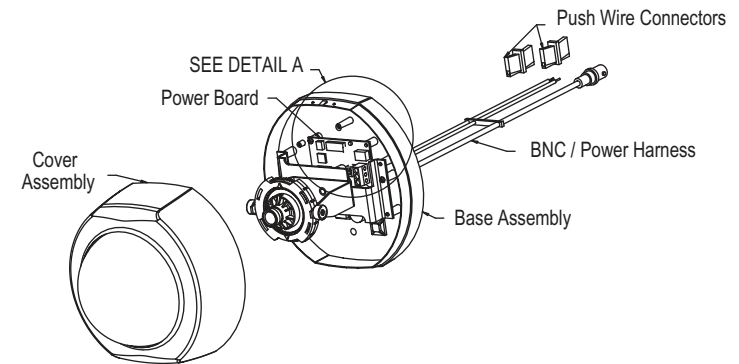
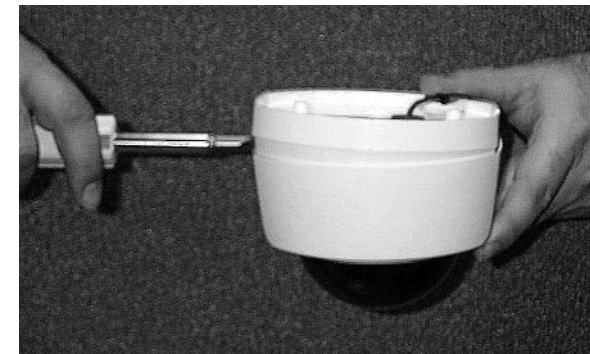

Figure 1 Dome Assembly

4. COVER REMOVAL & REPLACEMENT

1. To remove cover, insert the flat blade of a standard screwdriver into the housing seam between the cover and base and gently twist (see photo). The cover can also be removed by gripping the longer sides of the unit, squeezing, then pulling off the top piece.
2. To replace the cover, align it with the base and push it gently until it snaps into place.



5. INSTALLATION

Attention: Installation should be performed by qualified service personnel only in accordance with the National Electrical Code or applicable local codes.

Model No. Voltage Range

PAL Models 12 to 28VAC, 50 Hz or 12 to 28VDC

NTSC Models 12 to 28VAC, 60 Hz or 12 to 28VDC

5.1 Preparing the Unit

Remove the integrated camera/dome unit from the carton. If necessary, remove the tape securing the wiring harness to the backside of the unit.

5.2 Connecting Line Power & Video Signal

The wiring harness will have a BNC connector to accept video signal and two push-wire connectors to accept line power. For mounting to a single gang electrical box, run power and video lines through a knockout into the box. For mounting directly to a wall or ceiling, run power and video lines to the desired location.

Caution: Before proceeding, be sure to disconnect the line power from the cable to be installed into the unit. Be sure that the unit is of the proper line voltage type for line power being used.

5.2.1 Connecting Line Power

1. Prepare the line and neutral wires by stripping 9-11 mm (0.39 inch) from each wire. The push-wire connector is designed to accommodate AWG 20-16 wire.
2. **DC Applications:** The neutral/common wire for 12VDC supply is to be installed in the connector on the black wire. The 12VDC supply wire is to be installed in the connector on the red wire. This configuration should ensure that no flicker occurs in the picture when viewing fluorescent lighting. If flicker does occur, simply reverse the wires. Refer to step 4 for wire removal.

AC Applications: No specific wiring configuration is required.

3. Connect the line and neutral wires. To connect, press the button on the connector fully as indicated on the connector. Insert the stripped conductor into the square entry and release.
4. If wire removal is needed, press the button on the connector fully as indicated on the connector and withdraw the connector.

5.2.2 Connecting Video Cable

1. Route and connect video cable to BNC connector.

Note: Due to shipping and handling picture may be slightly out of focus when first powered, simply twist the lens until desired focus is reached.

5.3 Mounting

This unit is designed to mount to a standard single gang electrical box. Additionally, the unit can be mounted to a ceiling or wall without a gang box.

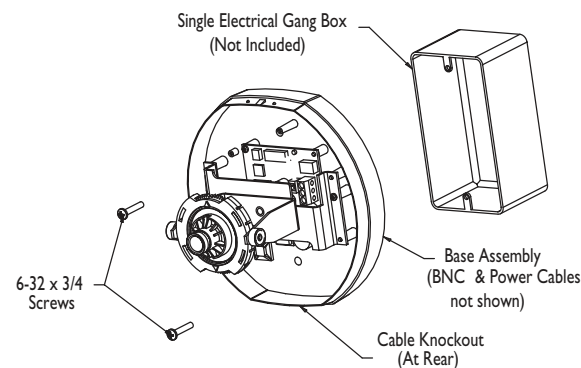

Figure 2 Mounting

1. When mounting to an electrical gang box, place the 2 included 6-32 x 3/4 screws through the unit's screw holes and mount directly to the box. When wall mounting, position the unit such that the cable knockout (see figure 2) is toward the floor. For mounting without a gang box, insert screws through holes and attach to anchors appropriate for the specific wall/ceiling type.
2. Secure the unit to the wall or ceiling.
3. After making camera adjustments, replace the dome cover to the unit.

6. CAMERA ADJUSTMENT

Set the camera to the desired position by performing the following steps.

1. Remove dome cover.
2. Camera module position can be adjusted both vertically and horizontally. The camera module can also be rotated for proper tilt orientation.
3. Adjust the camera at the pivot points and using the rotation knob, (see below) retighten thumbnuts as needed.

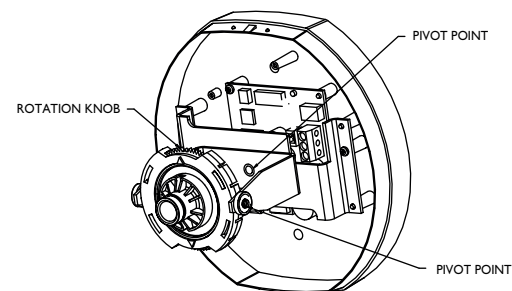

7. LINE LOCK / PHASE / BACKLIGHT COMPENSATION/ WHITE BALANCE SETTINGS

See Figure 3 for these adjustments. The dip switches on the power board control the settings for line lock, white balance and back light compensation.

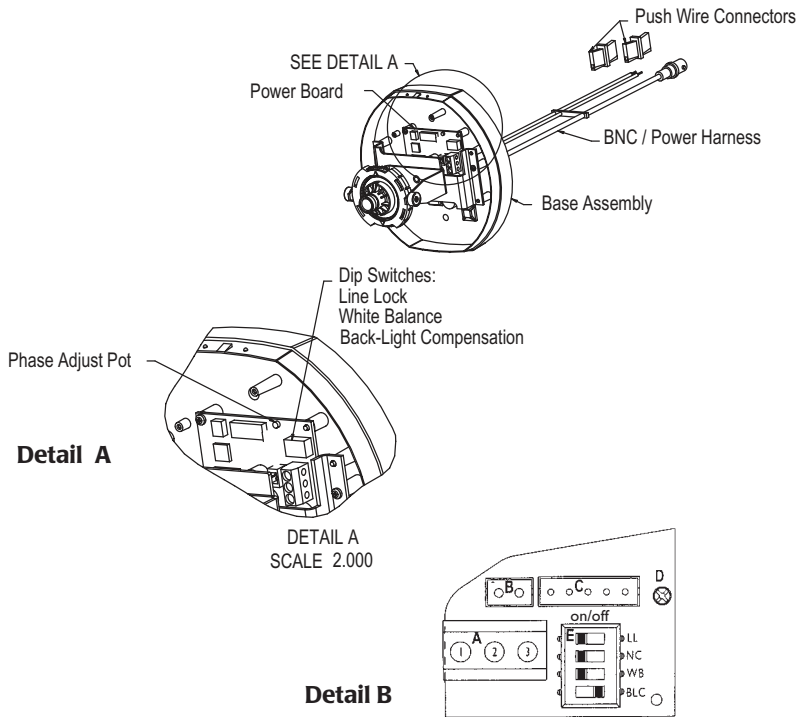

CAMERA MODULE ADJUSTMENTS AND CONNECTIONS

A - Power Block

1. Supply
2. Secondary GND (Do not connect)
3. Supply

(Supply accepts 24 Vac or 12Vdc, polarity independent, galvanically isolated from video GND)

B - Video Cable Output Connection

C - DC Iris Cable Connection

D - Vphase Adjustment

Adjust control until desired setting is achieved

E - Default Dipswitch Settings

- On - LL (Line Lock)
- NC (Not Connected)
- On - WB (White Balance)
- Off - BLC (Back Light Compensation)

**Figure 3 : LINE LOCK / PHASE / BACKLIGHT COMPENSATION/
WHITE BALANCE SETTINGS**

10

8. REPLACEMENT PARTS

Part no.	Qty	Part Description
315 3453 001	1	Dome Cover

9. CARE & MAINTENANCE

No special maintenance is required.

If dust should accumulate inside the dome cover, remove the dust with clean compressed air. For removal of heavy residues, rinse sparingly with water and immediately dry with pressurized air, taking care to avoid using a high pressure stream as damage to the dome cover may occur.

To clean the transparent dome cover, use any nonabrasive cleaning cloth with mild soap and water. Rinse with fresh water and dry with clean, compressed air.

10. DIMENSIONAL OUTLINE

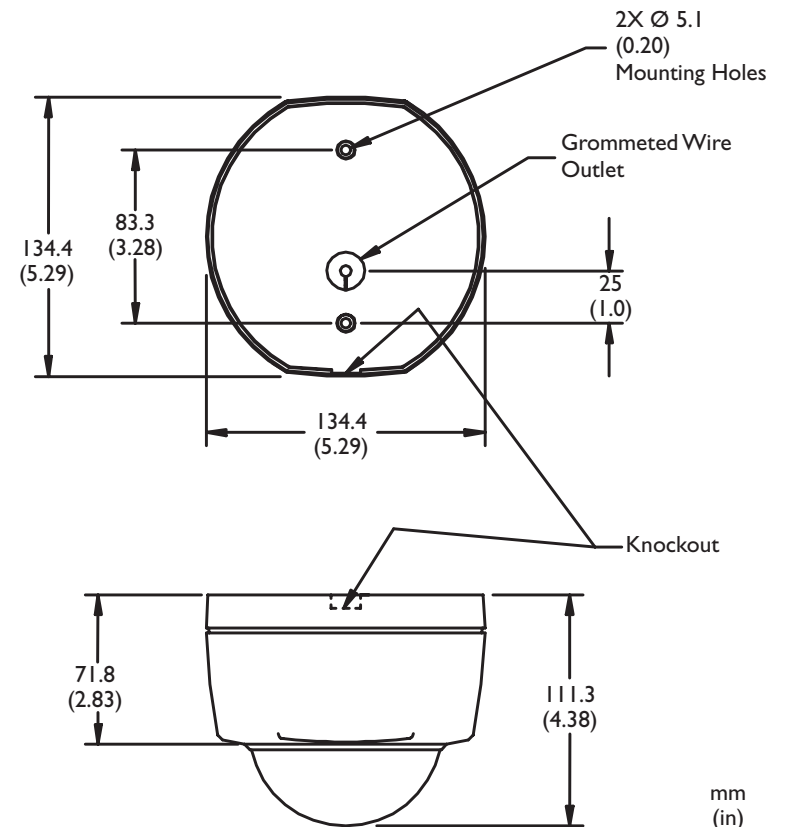

mm
(in)

11



mechtronics

©2002 Aigis Mechtronics

1124 Louise Road, Winston-Salem, NC 27107-5450

Tel: 336.785.7740 Fax: 336.785.7744

100 0042 001 AIG 10/02

Printed in U.S.A.

Data subject to change without notice