

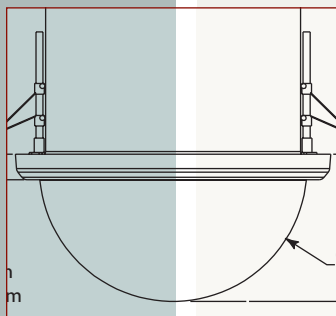

- For Fixed Cameras
- Plenum Ceiling Applications
- Concealed Camera Position with Minimal F-stop Loss
- Easy Installation
- Adjustable Viewing Direction

6-inch Dome Housing

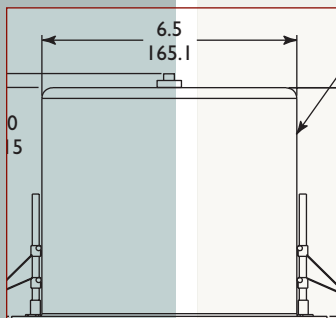
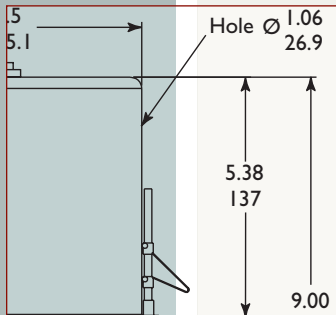

HS9349

The Aigis HS9349 dome housing accommodates fixed cameras and can be easily mounted in both sheet rock and standard drop ceilings using a quick-latch mechanism. The backbox is constructed from durable aluminum with conduit access and accommodations for safety cables making it ideal for use in plenum ceiling applications. Additionally, these units include a masked dome with a viewing window that conceals the camera/lens with minimal light reduction.

SPECIFICATIONS

MECHANICAL SPECIFICATIONS			
Housing	Construction		Aluminum Housing, acrylic dome. The dome is masked with a lightly tinted viewing area.
	Finish		Charcoal trim ring. (standard)
		W	White trim ring. (optional)
Weight		3.8 lb (1.7 kg).	
Camera Mounting			Two-arm camera support bracket, adjustable forward and backward, is included with each unit
ENVIRONMENTAL			
			Rated for indoor use only.
Temperature	Operating		+14 °F to +122 °F (-10 °C to +50 °C)
	Storage		-4 °F to +122 °F (-20 °C to +50 °C)
Humidity			0% to 90% relative, noncondensing.
ELECTROMAGNETIC COMPATIBILITY			
Safety			CE & UL

ACCESSORIES

IND6MK: Mounting kit with support rails
for suspended ceiling applications.

HS9349 - DIMENSIONAL OUTLINE

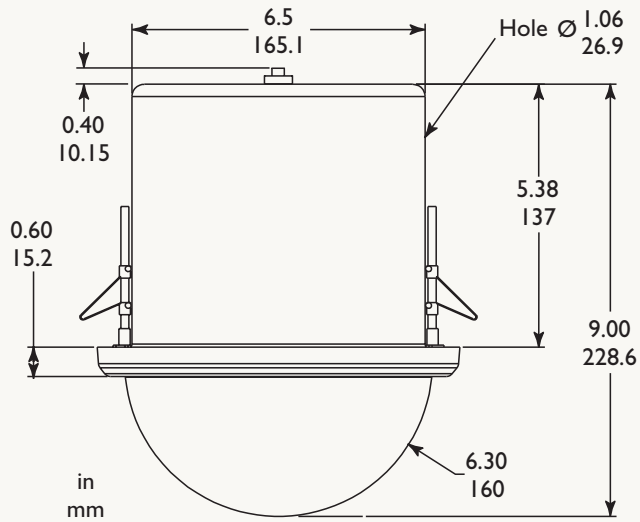

IND6MK - MOUNTING KIT ACCESSORY

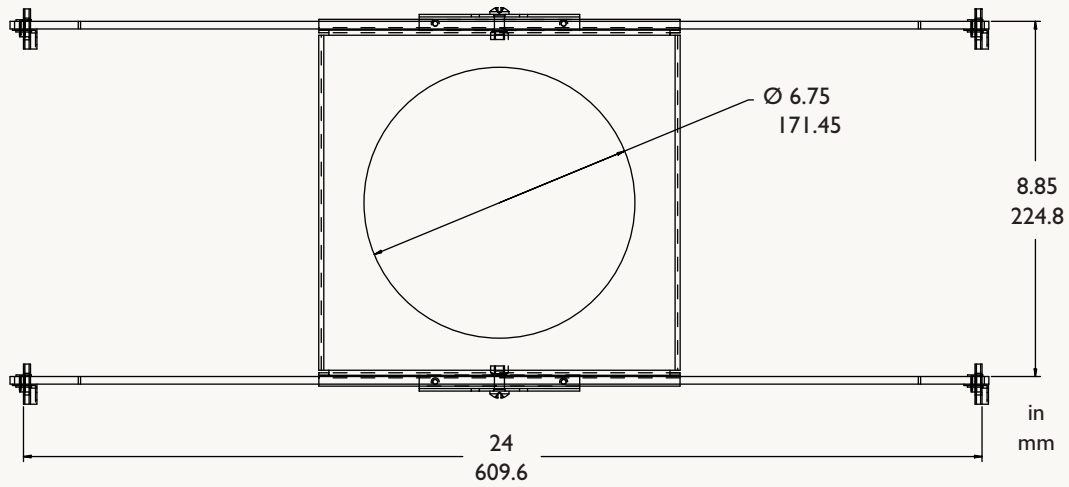



mechtronics

©2003 Aigis Mechtronics

1124 Louise Road, Winston-Salem, NC 27107-5450

Tel: 336.785.7740 Fax: 336.785.7744

www.aigismech.com

Data subject to change without notice

04/04 rev_01
Printed in U.S.A.