



**INSTALLATION INSTRUCTIONS FOR LONG DISTANCE MODULE: LDM-1
WIRING TO ALLSTAR CORP. MODELS U, T, GT, J, H, MO, MGH, AND LIGHT
DUTY M SERIES MODELS.**

- ISOLATE THE FOUR (4) WIRES THAT CONNECT THE THREE BUTTON STATION TO THE OPERATOR FIELD WIRING TERMINALS (THEY ARE CURRENTLY CONNECTED TO TERMINAL NO.s 1, 2, 3, AND 4). MARK THE WIRES FOR THEIR FUNCTION (#1 OPEN, #2 CLOSE, #3 COMMON, #4 STOP) AND REMOVE FROM THE FIELD WIRING TERMINALS.
- USING WIRE NUTS OR OTHER SUITABLE DEVICES, CONNECT THE THREE BUTTON STATION WIRES (REMOVED FROM THE OPERATOR FIELD WIRING TERMINAL STRIP IN STEP 1) TO THE LDM-1 MODULE "CONTROLS" SIDE WIRES. REFERENCE THE FIGURE BELOW.
- CONNECT THE LDM-1 MODULE "OPERATOR" SIDE GREEN, BLUE, WHITE, AND RED WIRES TO THE FIELD WIRING TERMINAL STRIP AS SHOWN IN THE FIGURE BELOW. THE FIELD WIRING TERMINALS ARE REPRESENTED IN THE FIGURE BELOW BY NUMBERS WITHIN CIRCLES.
- CONNECT THE LDM-1 MODULE "OPERATOR" SIDE BLACK WIRES TO 24 VAC POWER. THIS CAN BE ACCOMPLISHED IN ALL ALLSTAR OPERATORS BY CONNECTING TO THE SINGLE BUTTON RADIO TERMINAL STRIP TERMINAL NO.s 1 AND 3. THE TERMINALS ARE REPRESENTED IN THE FIGURE BELOW BY NUMBERS WITHIN A TRIANGLE. THE RADIO TERMINAL STRIP IS LOCATED NEAR THE LIMIT SWITCHES IN THE OPERATOR CONTROL BOX.
- LOCATE A SUITABLE MOUNTING AREA FOR THE LDM-1 WITHIN THE OPERATOR CONTROL BOX AND SECURELY MOUNT THE MODULE TO THE BOX.

ALL THREE BUTTON STATIONS MUST BE MOUNTED TO THE "CONTROLS" SIDE OF THE LDM-1 MODULE FOR BEST PERFORMANCE, THE THREE BUTTON STATION(S) SHOULD BE WIRED TO THE LDM-1 MODULE WITH #18 OR #20 WIRE.

DO NOT ATTEMPT TO CONNECT A CONTROL BY BRIDGING THE LDM-1 MODULE "CONTROLS" SIDE AND THE OPERATOR FIELD WIRING TERMINAL STRIP (CONNECTING ONE WIRE OF A CONTROL TO THE LDM-1 MODULE "CONTROLS" SIDE AND ONE WIRE OF A CONTROL TO THE OPERATOR FIELD WIRING TERMINAL STRIP). THE CONTROL WILL NOT OPERATE AND THIS CONNECTION WILL RESULT IN PERMANENT DAMAGE TO THE LDM-1 MODULE.

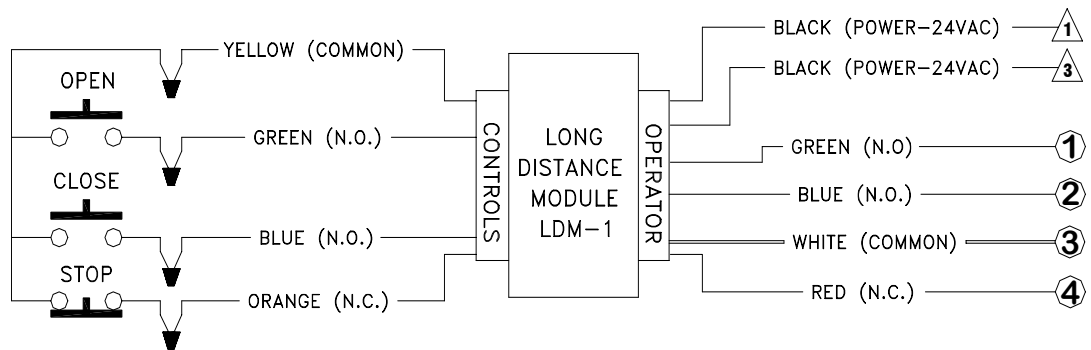

DOCUMENT # 100781-INSTR
COPYRIGHT cp ALLSTAR
CORP.
OCTOBER 2002



**INSTALLATION INSTRUCTIONS FOR LONG DISTANCE MODULE: LDM-1
WIRING TO ALLSTAR CORP. MODELS U, T, GT, J, H, MO, MGH, AND LIGHT
DUTY M SERIES MODELS.**

- ISOLATE THE FOUR (4) WIRES THAT CONNECT THE THREE BUTTON STATION TO THE OPERATOR FIELD WIRING TERMINALS (THEY ARE CURRENTLY CONNECTED TO TERMINAL NO.s 1, 2, 3, AND 4). MARK THE WIRES FOR THEIR FUNCTION (#1 OPEN, #2 CLOSE, #3 COMMON, #4 STOP) AND REMOVE FROM THE FIELD WIRING TERMINALS.
- USING WIRE NUTS OR OTHER SUITABLE DEVICES, CONNECT THE THREE BUTTON STATION WIRES (REMOVED FROM THE OPERATOR FIELD WIRING TERMINAL STRIP IN STEP 1) TO THE LDM-1 MODULE "CONTROLS" SIDE WIRES. REFERENCE THE FIGURE BELOW.
- CONNECT THE LDM-1 MODULE "OPERATOR" SIDE GREEN, BLUE, WHITE, AND RED WIRES TO THE FIELD WIRING TERMINAL STRIP AS SHOWN IN THE FIGURE BELOW. THE FIELD WIRING TERMINALS ARE REPRESENTED IN THE FIGURE BELOW BY NUMBERS WITHIN CIRCLES.
- CONNECT THE LDM-1 MODULE "OPERATOR" SIDE BLACK WIRES TO 24 VAC POWER. THIS CAN BE ACCOMPLISHED IN ALL ALLSTAR OPERATORS BY CONNECTING TO THE SINGLE BUTTON RADIO TERMINAL STRIP TERMINAL NO.s 1 AND 3. THE TERMINALS ARE REPRESENTED IN THE FIGURE BELOW BY NUMBERS WITHIN A TRIANGLE. THE RADIO TERMINAL STRIP IS LOCATED NEAR THE LIMIT SWITCHES IN THE OPERATOR CONTROL BOX.
- LOCATE A SUITABLE MOUNTING AREA FOR THE LDM-1 WITHIN THE OPERATOR CONTROL BOX AND SECURELY MOUNT THE MODULE TO THE BOX.

ALL THREE BUTTON STATIONS MUST BE MOUNTED TO THE "CONTROLS" SIDE OF THE LDM-1 MODULE FOR BEST PERFORMANCE, THE THREE BUTTON STATION(S) SHOULD BE WIRED TO THE LDM-1 MODULE WITH #18 OR #20 WIRE.

DO NOT ATTEMPT TO CONNECT A CONTROL BY BRIDGING THE LDM-1 MODULE "CONTROLS" SIDE AND THE OPERATOR FIELD WIRING TERMINAL STRIP (CONNECTING ONE WIRE OF A CONTROL TO THE LDM-1 MODULE "CONTROLS" SIDE AND ONE WIRE OF A CONTROL TO THE OPERATOR FIELD WIRING TERMINAL STRIP). THE CONTROL WILL NOT OPERATE AND THIS CONNECTION WILL RESULT IN PERMANENT DAMAGE TO THE LDM-1 MODULE.

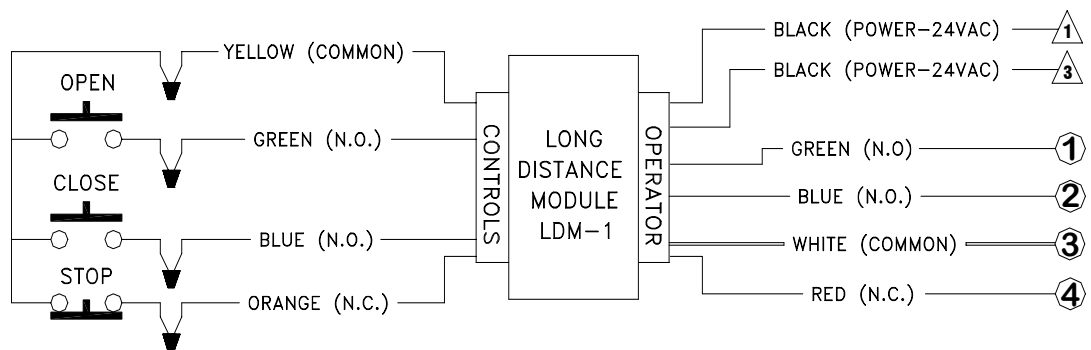

DOCUMENT # 100781-INSTR
COPYRIGHT cp ALLSTAR
CORP.
OCTOBER 2002